

## FMS-1000 Fuel Weigher

**Introduction:** The FMS-1000 Gravimetric Fuel Measuring System is a compact, high precision instrument for measuring specific fuel consumption of diesel and petrol engines developing up to 1000 kW. The FMS-1000's wetted parts are all stainless steel, enabling Reference and unusual fuels to be used.

The Photo below shows the main components of the FMS-1000 System: the Fuel Weigher, Control Unit, Fuel Fill Solenoid Valve (Stainless steel as required), CP128 Control and Monitoring Card (DL-FMS-02) Connection Loom and Fuel Weigher software component (not shown).

The FMS1000 system is controlled and monitored by CADETV12, this records and can display the data obtained. The fuel weigher uses a 20N loadcell to measure consumed fuel. It also cancels any vibration mechanically, as the construction is stiff and has no moving parts.

The benefits of this design include a high degree of linearity and a reduction of inaccuracies by not using a vibration dashpot.

The fuel cell has a volume of 1 Litre and is mounted on top of the 20N loadcell, the fuel cell has four ports all connected by lightweight bellows. These ports are for Fuel Feed, Fuel Supply, Fuel Return and Vent, as shown in the photo.



Calibration is achieved by automatic application of a 100gram calibration weight on to the fuel vessel. The resulting increase in the analogue output signal is used to calibrate the system at the prevailing fuel level.

When the system is not configured for operation by CADETV12 and the DL-FMS-02 card it can run in a hardware only mode, the Control Unit will maintain the fuel at a pre-set level, by opening and closing the fuel 'FILL' solenoid valve. This enables the FMS system to run as an in-cell header tank automatically.

### Steady State Fuel Measurement:

CADETV12 closes the solenoid valve so that fuel is taken only from the vessel when a fuel measurement is initiated. After a short settling time, the net mass of fuel taken from the vessel (over the desired sampling time) is measured. The CP128 card samples data at 10 kHz and returns the *averaged* value back to CADETV12 at up to 10 Hz. At steady state conditions the engine power is known and CADETV12 calculates brake specific fuel consumption.

### Dynamic Fuel Measurement:

The FMS-1000 is capable of monitoring fuel during a period of a test stage, or cycle, for a specific time as short as 100 ms. The stage, or cycle, is then repeated and the average fuel consumption rate calculated as a true dynamic reading.

# CP Data Sheet

## Specification:

Compatible Fuel Types	Petrol, Diesel (For Reference Fuels Contact CP)
Mass Signal Interface	0 to 5 V DC calibrated as 0 to 500 grams
Cal/Fill Interface Contact/Opto coupled	5 to 24 Volts DC
Flow Range	0 to 300 kg/hr
Temperature Range	0 to 65°C
Accuracy	±0.05% of reading, ±0.03 grams
Dimensions (Weigher) (HxWxD)	330 x 230 x 180 mm
Weight (Weigher)	7 kg
Pipe Connections	3/8" BSP(P) Female.

10/2003

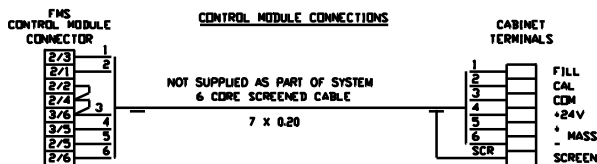
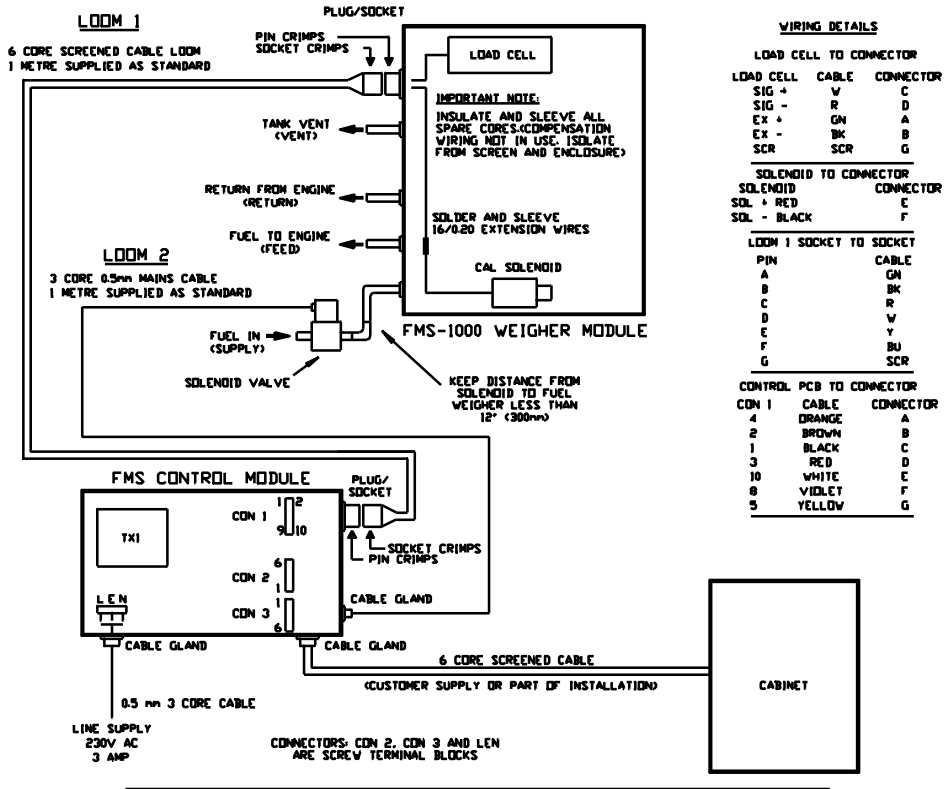

REFER TO SYSTEM DRAWINGS FOR TERMINAL BLOCK NUMBERS

### STANDARD LINK CONFIGURATION

- LINK 10 (FLYWHEEL DIODE ACROSS FILL SOLENOID)
- LINK 6 (CAL +24V IN)
- LINK 2 (FILL +24V IN)
- LINKS 11/12 (COUPLE SOLENOID SUPPLY TO 24V)

NOTE:  
LOOMS 1 AND 2 SUPPLIED AS PART OF COMPLETE SYSTEM